

(19) World Intellectual Property Organization
International Bureau



(43) International Publication Date
11 October 2001 (11.10.2001)

PCT

(10) International Publication Number
WO 01/75580 A2

(51) International Patent Classification?: **G06F 3/033**

[US/US]; 13019 Via Caballo Rojo, San Diego, CA 92129 (US). **HUBER, Rolf** [CH/US]; 7405 Charmant Dr. #2002, San Diego, CA 92122 (US).

(21) International Application Number: PCT/US01/10623

(22) International Filing Date: 2 April 2001 (02.04.2001)

(74) Agents: **PATEL, Milan et al.**; Patent Department, 6000 Connection Drive, Irving, TX 75039 (US).

(25) Filing Language: English

(26) Publication Language: English

(30) Priority Data:
09/542,450 4 April 2000 (04.04.2000) US

(81) Designated States (*national*): AE, AG, AL, AM, AT, AU, AZ, BA, BB, BG, BR, BY, BZ, CA, CH, CN, CR, CU, CZ, DE, DK, DM, DZ, EE, ES, FI, GB, GD, GE, GH, GM, HR, HU, ID, IL, IN, IS, JP, KE, KG, KP, KR, KZ, LC, LK, LR, LS, LT, LU, LV, MA, MD, MG, MK, MN, MW, MX, MZ, NO, NZ, PL, PT, RO, RU, SD, SE, SG, SI, SK, SL, TJ, TM, TR, TT, TZ, UA, UG, US, UZ, VN, YU, ZA, ZW.

(71) Applicant (*for all designated States except US*): **NOKIA MOBILE PHONES LIMITED** [FI/FI]; Patent Department, Keilalahdentie 4, FIN-02150 Espoo (FI).

(84) Designated States (*regional*): ARIPO patent (GH, GM, KE, LS, MW, MZ, SD, SL, SZ, TZ, UG, ZW), Eurasian patent (AM, AZ, BY, KG, KZ, MD, RU, TJ, TM), European patent (AT, BE, CH, CY, DE, DK, ES, FI, FR, GB, GR, IE,

(72) Inventors; and
(75) Inventors/Applicants (*for US only*): **BORIES, Jolie**

[Continued on next page]

(54) Title: A METHOD AND APPARATUS FOR A DYNAMIC KEYPAD DISPLAY

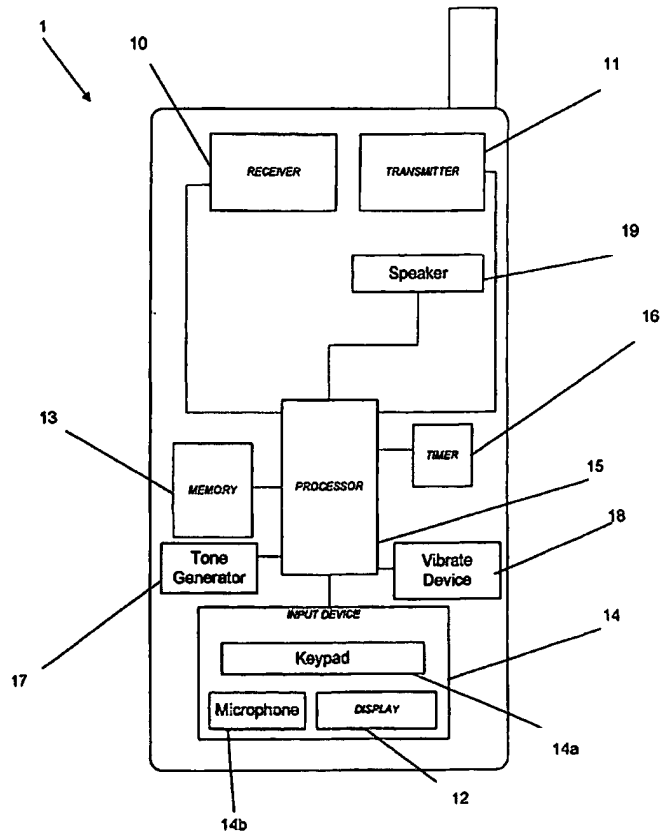

(57) Abstract: The present invention encompasses a electronic device for dynamically displaying key images based on operating mode of the mobile terminal. An electronic device has a plurality of operating modes (such as a phone mode, PDA mode, game mode, etc.), each operating mode having control images that represent function controls of the operating mode. The electronic device comprising two elements, first element being the main body and having a display and the second element being a cover (movable keypad) having transparent push buttons. When the movable element is covering the display, the electronic device dynamically displays the control images on the display, which are visible through the push buttons.

WO 01/75580 A2



IT, LU, MC, NL, PT, SE, TR), OAPI patent (BF, BJ, CF, CG, CI, CM, GA, GN, GW, ML, MR, NE, SN, TD, TG).

For two-letter codes and other abbreviations, refer to the "Guidance Notes on Codes and Abbreviations" appearing at the beginning of each regular issue of the PCT Gazette.

Published:

— *without international search report and to be republished upon receipt of that report*

A METHOD AND APPARATUS FOR A DYNAMIC KEYPAD DISPLAY

FIELD OF INVENTION

5 This invention relates to a method and apparatus for user interface in electronic devices and, more particularly, to a method and apparatus for providing dynamic keypad display in an electronic device.

BACKGROUND OF THE INVENTION

Many electronic devices, more particularly, mobile electronic devices use a
10 keypad for operating the electronic device. Some of these mobile electronic devices, such as mobile phones, have a keypad with push button keys to operate the functions of the mobile device. Other electronic devices, such as palm organizers or personal digital assistants (PDA), offer a large display area without a keypad and use a touch-screen display for entering data. In a
15 typical PDA, keys are displayed on the touch-screen display such that user may operate the functions by tapping the displayed key.

A typical mobile phone offers a keypad having a set of data entry keys (0-9, * and #), set of functional keys ("talk" and "end") and up, down, right and left arrow keys and the keypad is statically arranged and pre-labeled at time of
20 manufacture. The typical mobile phone also offers several operating modes with several function controls. It is very inconvenient for the mobile phone user when the user switches from one mode to another. However, the user is expected to know the operation of each key when functions associated with a pre-labeled key has changed based on the active operating mode. For
25 example, a pre-labeled key "2" may operate a "up" function when in game mode versus entering number 2 when in phone mode.

A typical PDA offers daily schedules, games, e-mails and has a large display area. This large area is very useful. The large display area provides better visibility and convenience when reading and entering data. Depending on the
30 operation mode of the organizer, the large display area may be reduced in

order to display the control images (keys) on the display. The reduction of the size of the display, however, causes the user to lose large visible area, thereby defeating the purpose of the large display area.

5 An electronic device that is a combination of mobile phone and PDA are becoming popular. A typical combined electronic device that is mobile phone and PDA, offers a keypad to control the phone functions while in phone mode and a large display area for displaying information while in PDA mode. However, these devices continue to offer the keypad with static keypad display and continue using portion of display area for displaying keys when
10 providing a key display. Furthermore, most of these combined units allow the user to use only one method of input, either the keypad or the touch-screen, for operating the device.

An electronic device that dynamically labels the keys of a keypad based on the operating mode of a device would be very useful. Also, an electronic
15 device that offered a large display area and capability of receiving input, for operating the device, via the dynamic keypad and/or the touch-screen display would be very useful.

SUMMARY OF INVENTION

The present invention encompasses a mobile terminal having a plurality of
20 operating modes (such as a phone mode, PDA mode, game mode, etc.), with each operating mode having control images that represent function controls of the operating mode. The mobile terminal may comprise two elements, the first element being the main body and having a display and the second element being a cover (movable keypad) having transparent push buttons.
25 The second may be element coupled to the main body, and cover at least a portion of the display when placed in a first position and expose the display when placed in a second position. When the movable element covers the display, the mobile terminal may display the control images, which are visible through the push buttons, and receive input when the pushbuttons are
30 actuated. For example, if the operation mode of the mobile terminal was "phone mode," then one of the functional controls may be data entry keys with alphanumeric (0-9, *, #) control images and communication ("talk" and "end")

control images. When in phone mode, these alphanumeric control images are displayed on the display under the pushbuttons of the second element, which is covering the display. When the user actuates a pushbutton with control image "2" for example, the number "2" is accepted as data by the mobile terminal. If the user switches to a different mode, for example a game mode having directional keys (up, down, left, right) control images, are dynamically switched from alphanumeric control images to the arrow control images. The advantage of this invention is that the mobile terminal dynamically changes the display and provides a different keypad for input, based on the operation mode of the mobile terminal.

The present invention also encompasses an apparatus and method of receiving input from the movable element and/or the touch-screen display when the movable element is in a second position, exposing the display. The advantage is that user may enter data using the push buttons or the touch-screen display.

Other Implementations may have similar or other advantages, as will be clear from the description and claims that follow.

20

BRIEF DESCRIPTION OF THE DRAWINGS

FIG. 1 illustrates a block diagram of a mobile station into which an embodiment of the invention may be implemented;

FIGs. 2A–2D show views of an implementation of a mobile station according to an embodiment of the invention;

FIG. 3 shows views of hinge mechanism implementation in a mobile station according to another embodiment of the invention;

FIGs 4A–4D show display patterns of key images based on operating modes while a keypad portion of a mobile station is in a first position according to an embodiment of the invention.

30

FIGs 5A-5D show display patterns of key images based on operating modes while a keypad portion of a mobile station is in a second position according to an embodiment of the invention; and

5 FIGs. 6A-6C shows a software module depiction of an embodiment of the invention.

DETAIL DESCRIPTION OF THE INVENTION

FIG. 1 is a block diagram of the mobile station 1, according to an embodiment of the invention. Generally, mobile station 1 includes receiver 10, transmitter 11, and controller (which may also be known as a processor) 15 that is coupled to transmitter 11 and receiver 10. Processor 15 initiates the transmission of outgoing signals and processes incoming signals. These signals may include signaling information in accordance with the air interface of the applicable cellular or digital system, and also user speech and/or user generated data.

15 A user interface includes a Liquid Crystal Display (LCD) 12 which comprises a touch-screen display, tone generator 17, speaker 19, vibrate device 18 and user input device 14 comprising keypad 14a, all of which are coupled to processor 15. The input device may also comprise microphone 14b for generating input. The input device may further include the touch-screen display 12. Mobile station 1 also comprises timer 16 (also referred to as a clock chip) coupled to processor 15 for synchronizing the operations of processor 15 and tracking time.

Mobile station 1 also includes various memories, shown collectively as memory 13. Memory 13 includes a plurality of stored constants and variables that are used by processor 15 during the operation of mobile station 1. For example, memory 13 stores the values of the various feature parameters and the number assignment module (NAM). An operating program for controlling the operation of processor 15 is also stored in memory 13 (typically in a read only memory). Memory 13 is also used to store data provided by the user through the user interface. Furthermore, memory 13 is used to hold the subprograms or sub-processes for controlling the operation of mobile station 1

25
30

and carrying out the embodiment of the invention. The operating program in memory 13 includes routines for providing plurality of operating modes and dynamic keypad display functions according to an embodiment of the invention.

5 Referring now to FIGs. 2A–2D, therein are shown views of an implementation of mobile station 1 that provides dynamic keypad display according to an embodiment of the invention. Mobile station 1 has two elements. The first element comprises a body portion 200 and the second element comprises keypad portion 202. The body portion 200 having an outer surface 204 and a
10 touch-screen display 12 having a display area is disposed on the outer surface 204 of the body portion 200. Disposed on side of the body portion 200 is a power switch 220 for turning the mobile station 1 on or off. The keypad portion 202 has a keypad 14a (not shown), the keypad 14a comprises a plurality of transparent pushbutton keys 214. The keypad portion 202
15 having front and back side 216 and 218. The embodiment of the invention allows the pushbutton keys 214 to be actuated from front or back side 216 and 218 of the keypad portion 202.

FIGs 2A and 2C shows the keypad portion 202 in the first position such that
20 the keypad portion 202 is covering portion of the display 12. When the keypad portion 202 is in first position, the pushbutton keys 214 are adjacent to the touch-screen display 12 such that any key images displayed on the display 12 is visible through the transparent keys 214. Also, the pushbutton keys 214 are adjacent to the touch-screen display 12 such that a user of the mobile
25 station 1 may enter input by actuating any of the pushbutton keys 214. In the first position, the keypad portion 202 is seated on the body portions 200, the such that actuating any of the pushbutton keys 214, touches (or taps) the touch-screen display 12, thereby generating input signals. In the first position, user of the mobile station 1 may enter data by actuating the pushbutton keys
30 214 from the front side 216 of the keypad portion 202.

FIG 2B and 2D shows the keypad portion 202 in the second position such that the keypad portion 202 is exposing the display 12. When the keypad portion

202 is in the second position, the user of the mobile station 1 may enter data by touching (or tapping) the touch-screen display 12 or actuating the pushbutton keys 214 from the back side 218 of the keypad portion 202.

5 In the operation of the mobile station 1, the keypad portion 202 moves from first position to second position or from second position to the first position based on the use of the mobile station 1. In an embodiment of the invention, the keypad portion 202 comprises hinges 300a and 300b forming a hinge axis 301. The body portion 200 comprises hinge receiving portion 302. The hinge
10 receiving portion 302 comprises pair of knobs 303a and 303b and a pair of hinge seats 304a and 304b. The keypad portion 202 is coupled to the body portion 200, wherein the hinges 300a-b are seated at the hinge seats 304a-b and attached to the knobs 303a-b, such that keypad portion 202 rotates about the hinge axis 301, and may be seen in the detail of FIG. 3. It should be noted
15 that, as in an alternative embodiment, a slide mechanism may be used to couple the keypad portion 202 to the body portion 200 wherein the keypad portion 202 may slide from first position to the second position. In the embodiment of the invention a keypad contact 306 is located at hinge 300a, the keypad contact 306 consisting of conventional conductive material and is
20 electrically coupled to each pushbutton keys 214. A body contact 308 consisting of a conventional conductive material is disposed at hinge seat 304a, the body contact 308 is coupled to the processor 13. The keypad contact 306 and body contact 308 are positioned such that the keypad contact 306 presses against body contact 308 when the keypad portion 202 is rotated
25 from first position to second position, wherein an electrical connection is completed. When the keypad portion 202 is rotated from the first position to the second position or from second position to the first position, a keypad portion position change signal is generated and received by the processor 13.

30 FIG 4A-D shows examples of operating modes the mobile station 1, wherein the keypad portion 202 is in first position. When the keypad portion 202 is in the first position, the mobile station 1 may be in phone mode, shown in FIG 4A. In the phone mode, the processor 15 displays control images (or key

images) representing function controls of the phone mode on the display 12. The first display area 400 of the display 12 is reduced by the processor 15 to generate a second area 402 which is covered by the keypad portion 202. The key images are grouped together in a pre-determined pattern 406, shown FIG 4B, such that when displayed on the second area 402, the key images are visible through the transparent push-button keys 214 to the user of the mobile station 1 as shown in FIG 4A. If the user selects a different mode, for example, a game mode, as shown in FIG 4C and 4D, the processor 15 displays a different pattern of key images 408 representing function controls of the game mode on the second area of the display 12 of the mobile station 1. For example, in the game mode, arrow key images are provided instead of alphanumeric key images for function control of the mobile station 1. Depending on the manufacturer, the mobile station 1 may comprise a plurality of operating modes, each operating mode having key images that represents a function control of the operating mode.

FIG 5A-B shows examples of operating modes of the mobile station 1, wherein the keypad portion 202 is in second position. When the keypad portion 202 is in the second position, the mobile station 1 may be in phone mode, shown in FIG 5A. In phone mode, the processor 15 displays control images (or key images) 500 representing function controls of the phone mode on the push-button keys 214. In an embodiment of the invention, an optical fiber may be embedded within each transparent push-button key to illuminate a key image within each push-button key. The optical fiber may communicate in a conventional method with a light source (not shown) and the processor 15 of the mobile station 1 to display key images on the pushbutton keys 214. Note that alternative methods of displaying key images on the pushbutton keys 214 may be used without departing from the invention. In the second position, the display 12 is exposed and the processor 15 utilizes the first area of display 12 for displaying information. The key images 500 are grouped together in a pre-determined pattern and are displayed on the push-button keys 214 of the keypad portion 202 as shown in 5B. If the user selects a different mode, for example a game mode

as shown in FIG 5C and 5D, the processor displays a different pattern of key images 502 representing function controls of the game mode on the push-button keys 214.

5 In accordance with an aspect of this invention the operating program in memory 13 includes, a plurality of operating modes, plurality of key images, a plurality of pre-determined patterns of key images and a routine to allow a user to modify the predetermined pattern. Using the menu function, the user may set up the display pattern of a key image and assign a key to use for
10 displaying the key image. Note that manufacturers may provide predetermined display pattern and key assignment associated with each operating mode without allowing the user to modify the patterns or key assignments.

Reference is made to FIG. 6A for illustrating a keypad portion position
15 change task 600. This task is activated upon the processor 15 receiving a keypad portion position change signal, described above, when the keypad portion 202 is moved from one position to another position. At block 602, processor 15 determines if the keypad portion 202 has moved from a first position to a second position or from second position to the first position. If
20 the keypad portion 202 is moved to a the first position, then display covered task at block 604 is executed. Otherwise, display exposed task at block 606 is executed.

Reference is made to FIG 6B for illustrating a display covered task 604. This task is activated if keypad portion 202 is in first position covering the
25 display 12 at power on or when keypad portion 202 is moved from second position the first position. At block 612, the processor 15 determines the current operation mode of the mobile station. Using the determined operation mode, at block 614 and 616, the processor 15 accesses the memory 13 to acquire a display pattern and display pattern parameters associated with the
30 operating mode. At block 618, the processor 15 splits the display area to form a second display area by reducing the size of the first display area. The size of the second area is pre-determined by the display area covered by the

keypad portion 202. At block 620, the processor 15 displays the key images according to the display patterns and parameters using the second display area. At block 622, the processor 15 begins receiving input from display 12 upon the actuation of the push button keys 214.

5 Reference is made to FIG 6C for illustrating a display exposed task 606. This task 606 is activated if keypad portion 202 is in second position exposing the display 12 at power on or when keypad portion 202 is moved from first position the second position. At block 624, the processor 15 determines the current operation mode of the mobile station 1. Using the
10 determined operation mode, at block 626 and 628, the processor 15 accesses the memory 13 to acquire a display pattern and display pattern parameters associated with the operating mode. At block 630, the processor 15 extends the display area by removing second display area thereby forming the first display area. At block 632, the processor displays, on the push button keys
15 214 of keypad portion 202, the key images according to the display patterns and parameters accessed in block 626 and 628. At block 634, the processor 15 begins receiving input from push-button keys 214 upon the actuation of pushbutton keys 214 or from the display 12 or upon actuating the touch screen area of the display 12.

20 As examples, the method and apparatus may also be implemented in electronic devices, such as PDA, calculators, GPS devices, landline telephones, computers, televisions, radios, remote control devices operating a television display, and other devices having display and keypad for input capability. The method and apparatus may be realized by implementing any
25 operating modes, such as map mode, TV control mode, VCR control mode, WAP mode or menu mode.

 Thus, while the invention has been particularly shown and described with respect to preferred embodiments thereof, it will be understood by those skilled in the art that changes in form and scope may be made thereon without
30 departing from the scope and spirit of the invention.

CLAIMS

What is claimed is:

- 1 1. An electronic device having a plurality of operating modes, each operating
2 mode having control images that represent function controls of the operating
3 mode, said electronic device comprising:
4
5 a first element having an outer surface and a display disposed therein
6 on the outer surface;
7 a second element coupled to the first element, the second element
8 having at least one transparent push button key, and covering a least
9 portion of the display when placed in a first position and exposing the
10 display when placed in a second position; and
11 a processor coupled to the display, the processor for displaying control
12 images on the display when the second element is in the first position
13 such that the control images are visible through the push buttons, the
14 processor, further, for receiving input when the at least one transparent
15 push button key is pushed.
- 1 2. An electronic device in accordance with claim 1, wherein
2 the display further comprises a touch screen display area defining a first
3 display area; and
4 said processor, further, for generating a second display area on the
5 display when the second element is in the first position and said second
6 display area is covered by the second element.
- 1 3. An electronic device in accordance with claim 2, wherein
2 said processor is coupled to the second element when the second element
3 is in the second position; and
4 said processor, further, displays the control images on the at least one
5 transparent push button key of the second element.
- 1 4. An electronic device in accordance with claim 3, wherein
2 said second element further comprises at least one hinge; and

3 said first element further comprises at least one hinge receiving
4 portion, each of the at least one hinge receiving portion having a
5 hinge seat and a knob; and, wherein each of the at least one hinge of
6 the second element is seated in one of the at least one hinge seat
7 and attached to one of the at least one knob of the first element.

1 5. An electronic device in accordance with claim 4, wherein
2 said at least one hinge and said at least one hinge receiving portion form a
3 hinge axis and
4 said second element is rotatable about the hinge axis from first position to
5 the second position.

1 6. An electronic device in accordance with claim 1, wherein,
2 said plurality of operating modes comprises a game mode and
3 the control image comprise at least one arrow key image representing
4 an up function control of said game mode.

1 7. An electronic device in accordance with claim 2, wherein,
2 the processor, further removes the second display area when the second
3 element is in the second position.

1 8. An electronic device in accordance with claim 1, wherein,
2 said electronic device comprises a mobile terminal; and
3 said plurality of operating modes comprises a mobile phone mode and
4 a PDA mode.

1 9. An electronic device in accordance with claim 7, wherein,
2 said first element comprises a personal digital assistant; and
3 said plurality of operating modes comprises a PDA mode and a phone
4 mode.

1 10. An electronic device in accordance with claim 2, wherein,
2 the processor, further, receives input from the touch screen display
3 area when the second element is in the first position.

- 1 11. An electronic device in accordance with claim 2, wherein,
2 the processor, further, for receives input from the push button keys
3 when the second element is in the second position.
- 1 12. A method for displaying control images representing functional control of
2 at least one operational mode of an electronic device, the method comprising
3 steps of:
- 4 detecting if a keypad portion is in a first position or in a second position;
- 5 displaying, in response to detecting that the keypad portion is in the first
6 position, the control images on a display visible through at least one push
7 button key of the keypad portion; and
- 8 receiving input when at least one of the push button keys is actuated.
- 1 13. The method of claim 12, wherein the step of detecting comprises a step of
2 receiving a signal when the keypad portion moves to the second position from
3 a first position.
- 1 14. The method of claim 12, wherein the step of displaying comprises a step
2 of determining the current operating mode the electronic device.
- 1 15. The method of claim 14, wherein the step of displaying comprises a step
2 of accessing, in response to determining the current operating mode, a
3 display patterns associated with the operating mode from a memory of the
4 electronic device.
- 1 16. The method of claim 12, wherein the step of displaying comprises a step
2 of generating a second display area which is covered by the keypad portion.
- 1 17. The method of claim 12, wherein the step of receiving input comprises a
2 step of receiving input from the display.

1 18. A method for displaying control images representing functional control of
2 at least one operational mode of an electronic device, the electronic device
3 comprising a first element having a display and a second element covering a
4 least portion of the display when placed in a first position and exposing the
5 display when placed in a second a position, the method comprising steps of:

6 detecting if the second element is in the first position;

7 displaying, in responsive to detecting that the second element having
8 push button keys is in the first position, the control images on the display,
9 visible through at least one push button key, when the second element is
10 in the first position; and

11 receiving input when at least one of the push button keys is actuated.

1 19. A processor for an electronic device, the electronic device having a
2 plurality of operating modes, each operating mode having control images that
3 represent function controls of the operating mode, said processor comprising:

4 an operating program comprising steps of,

5 determining if the second element is in the first position;

6 displaying using the processor, in responsive to detecting that the
7 second element having push button keys is in the first position, the
8 control images on the display when the second element is in the first
9 position; and

10 processing input when at least one of the push button keys is
11 actuated.

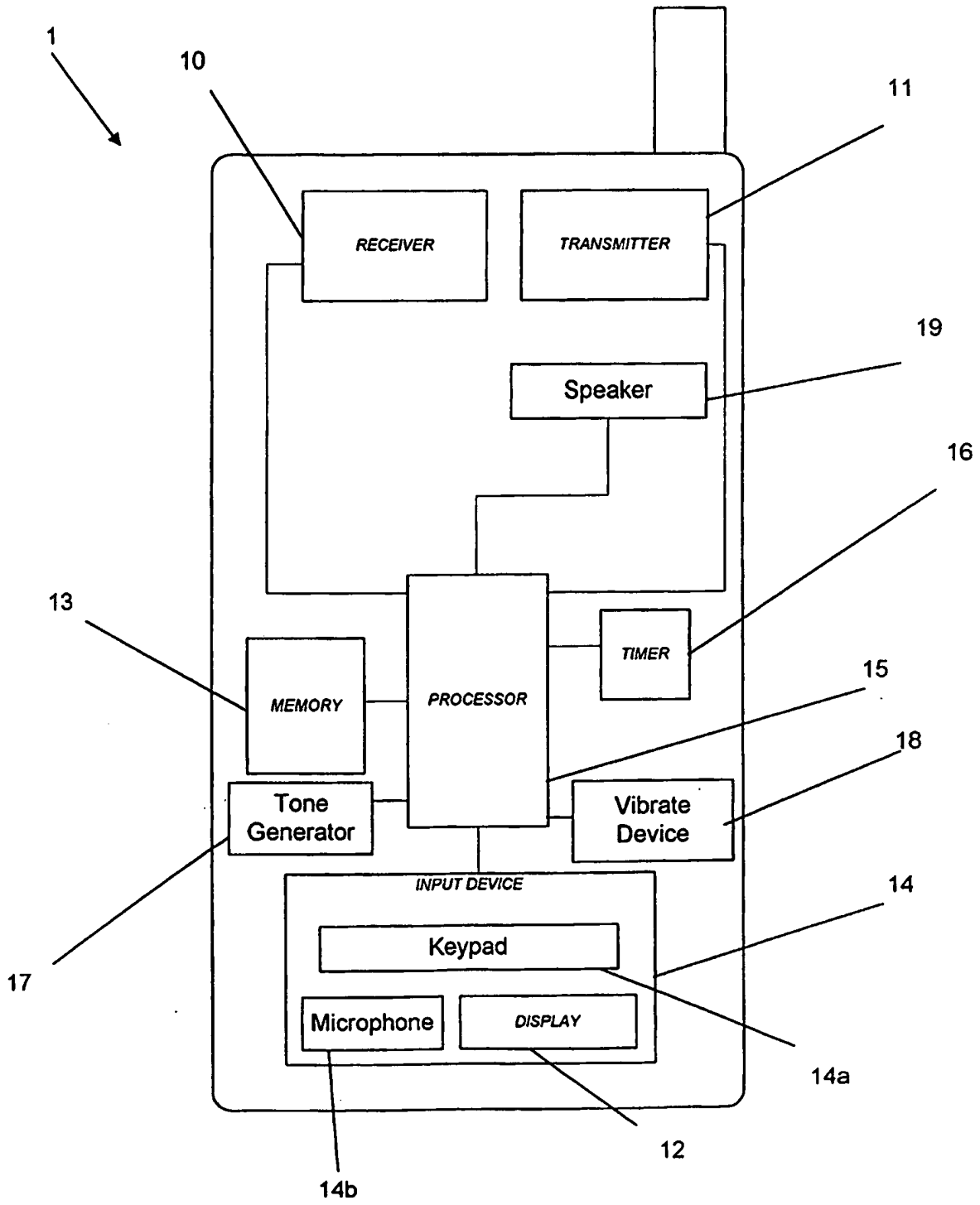

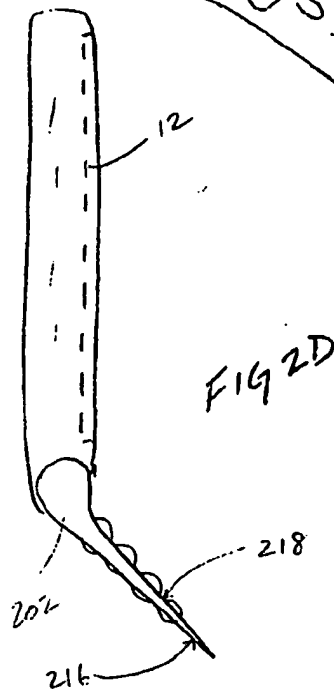
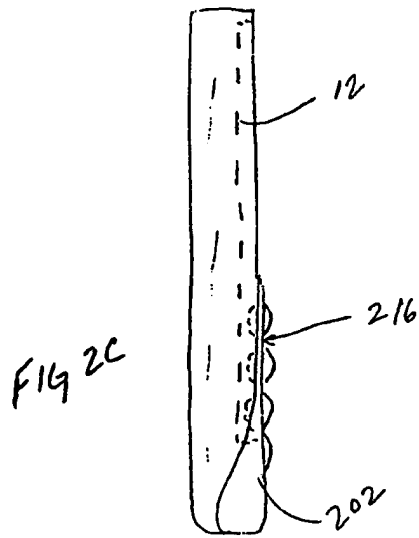
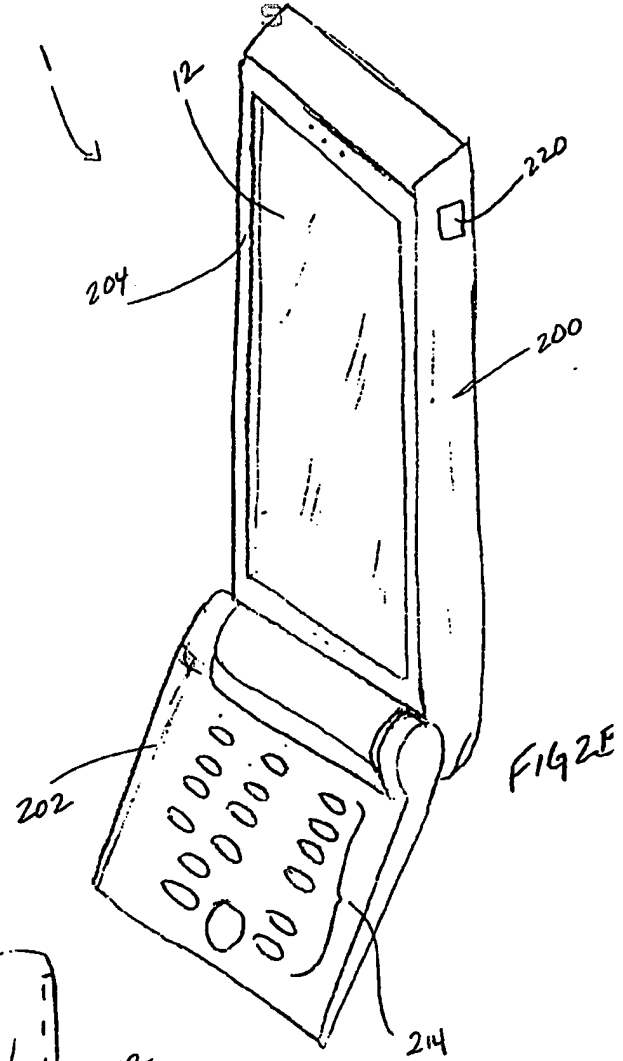
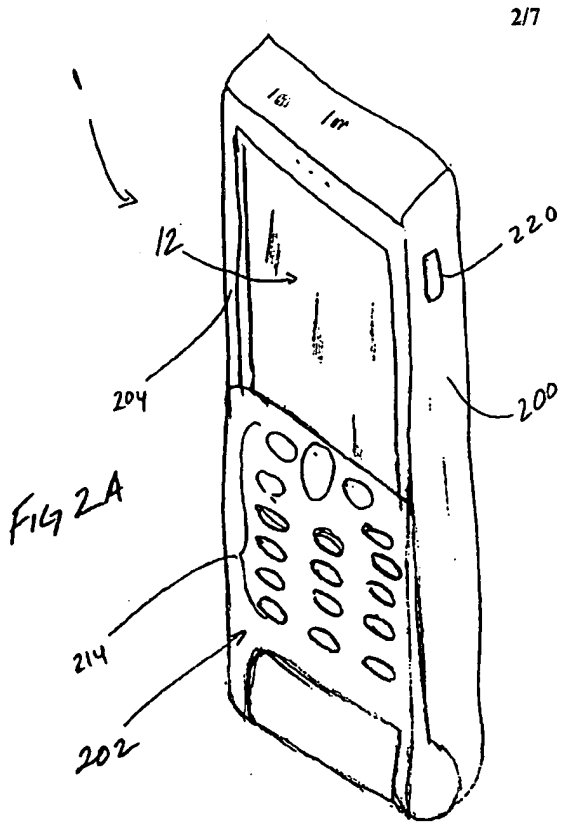

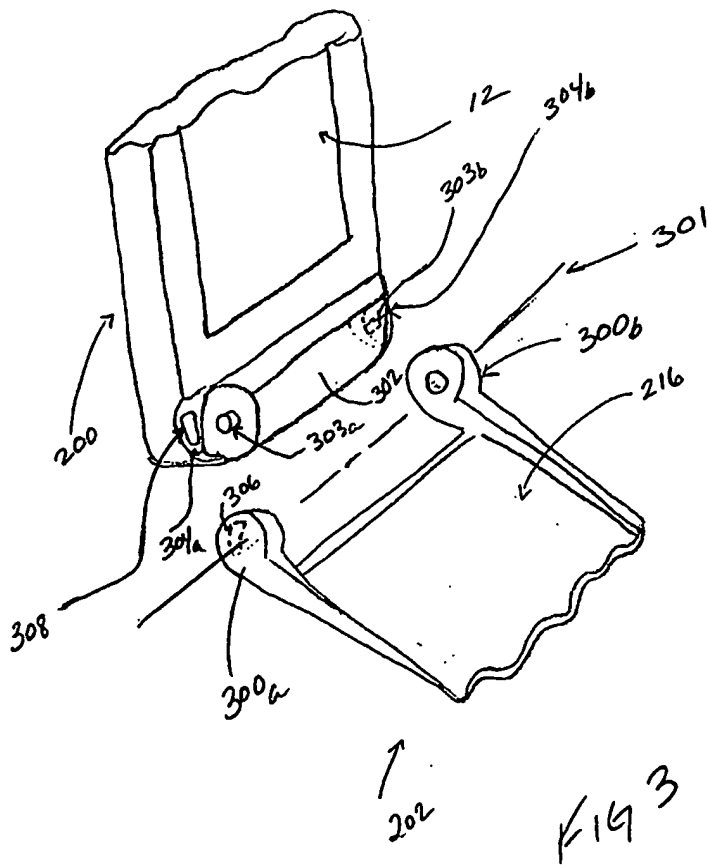

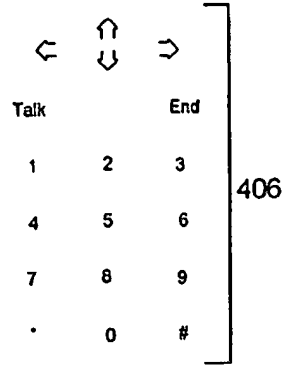
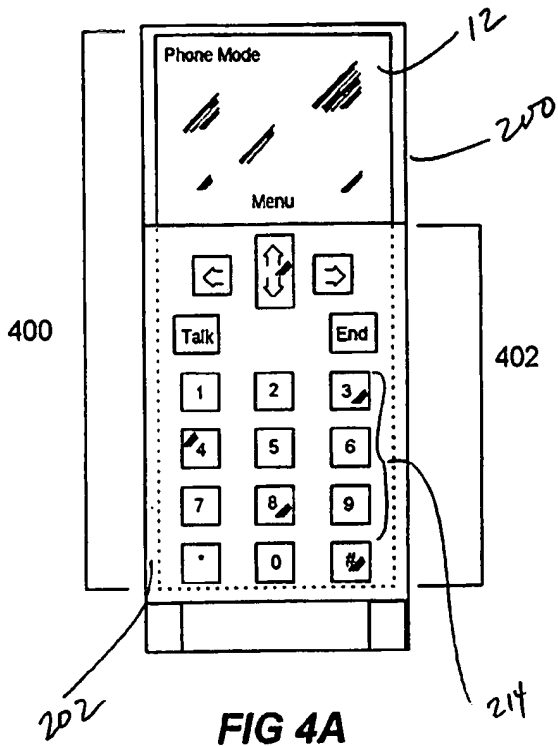

1

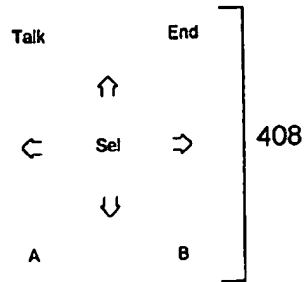
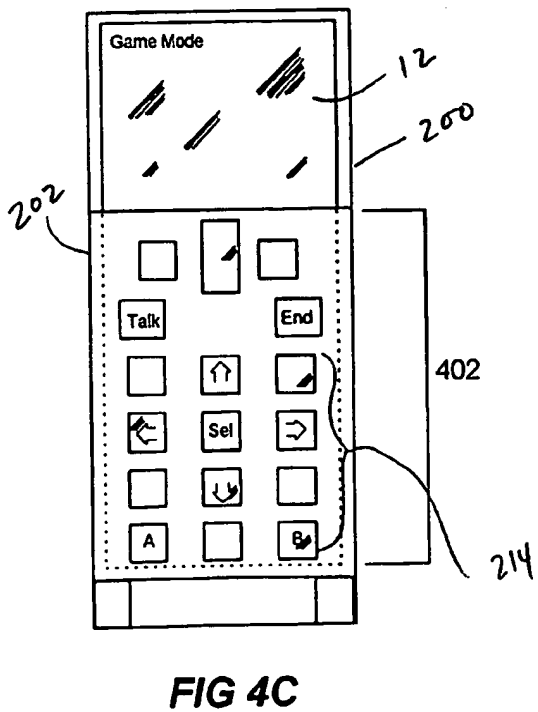

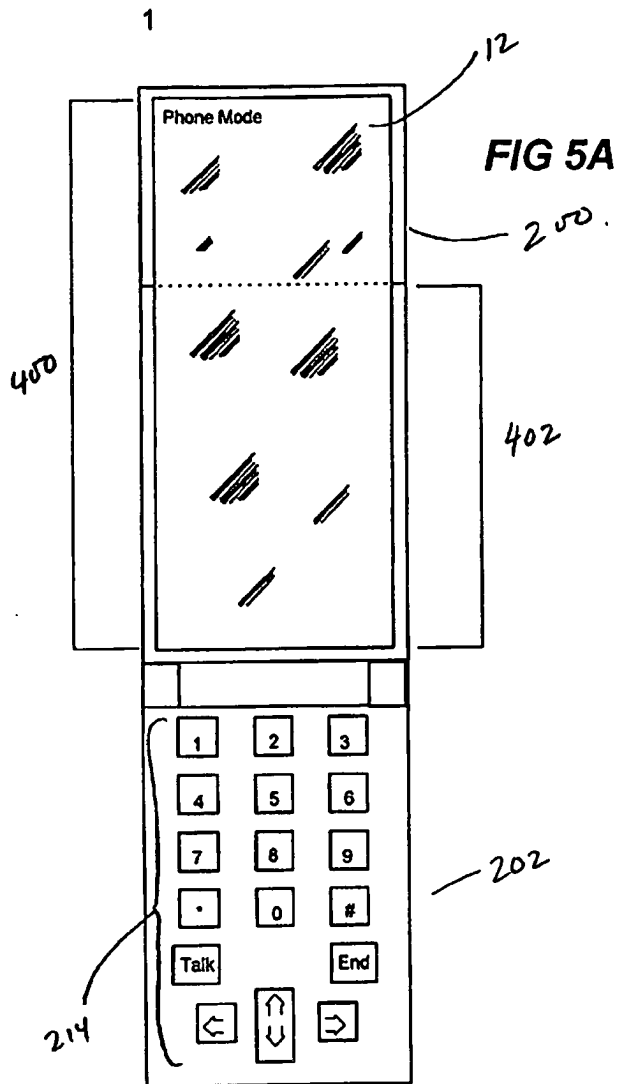
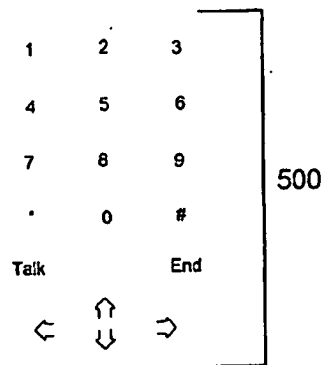

FIG 5A

FIG 5B



1

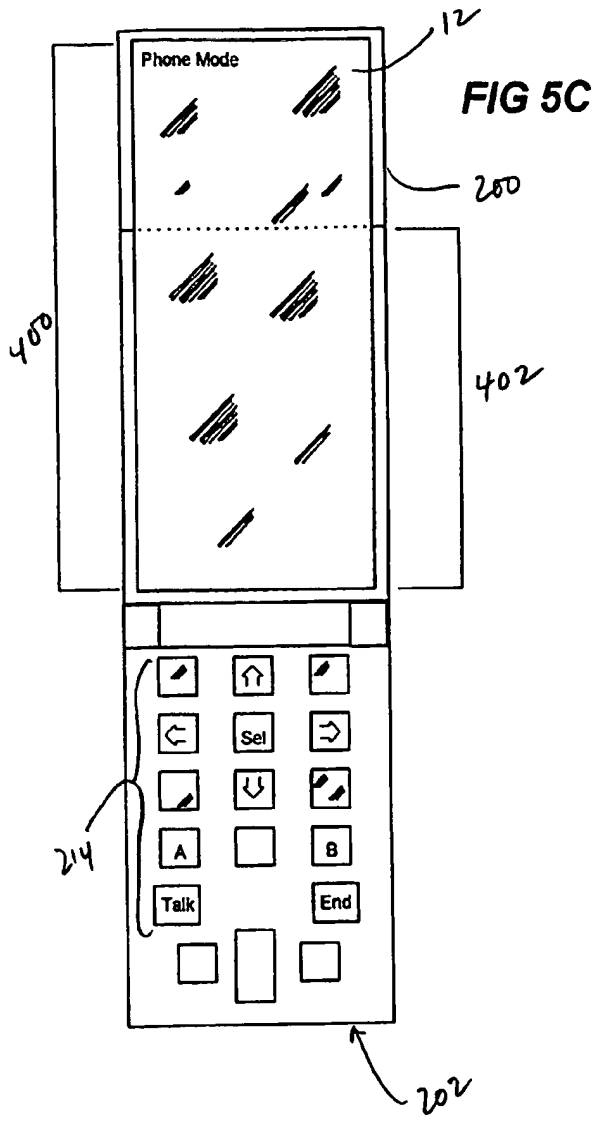
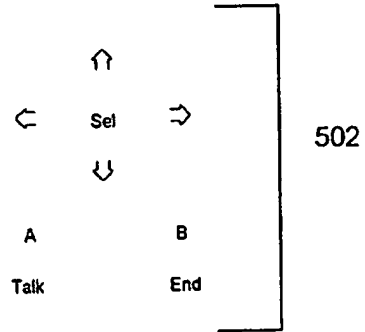

FIG 5D



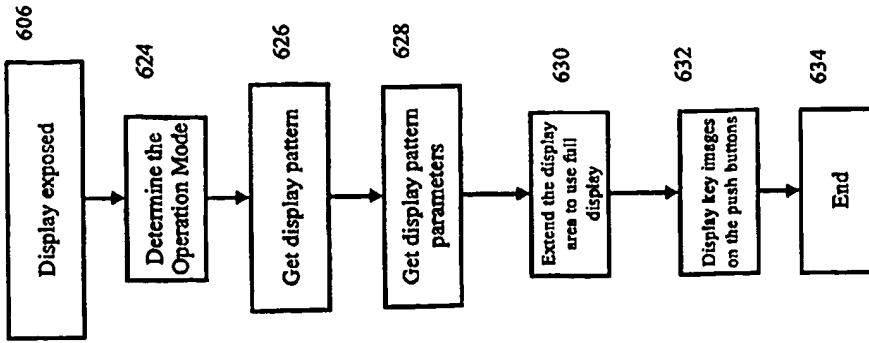

FIG 6C

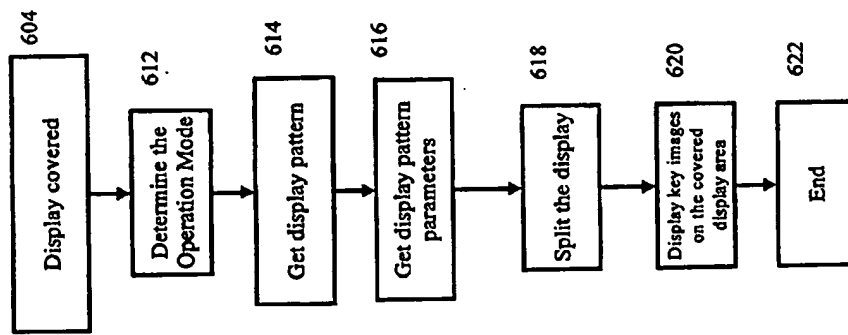

FIG 6B

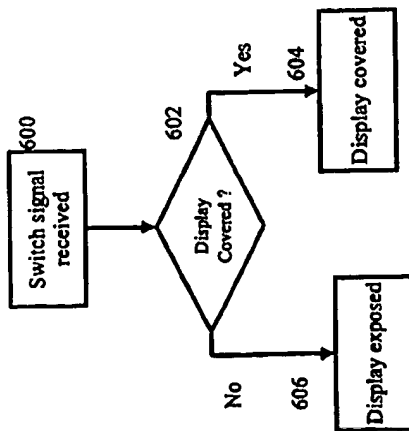

FIG 6A